



# CONFLEX<sup>®</sup>

# E-250

## Automatic L-Sealer

A "Smart," Proven Performer at an Excellent Value!

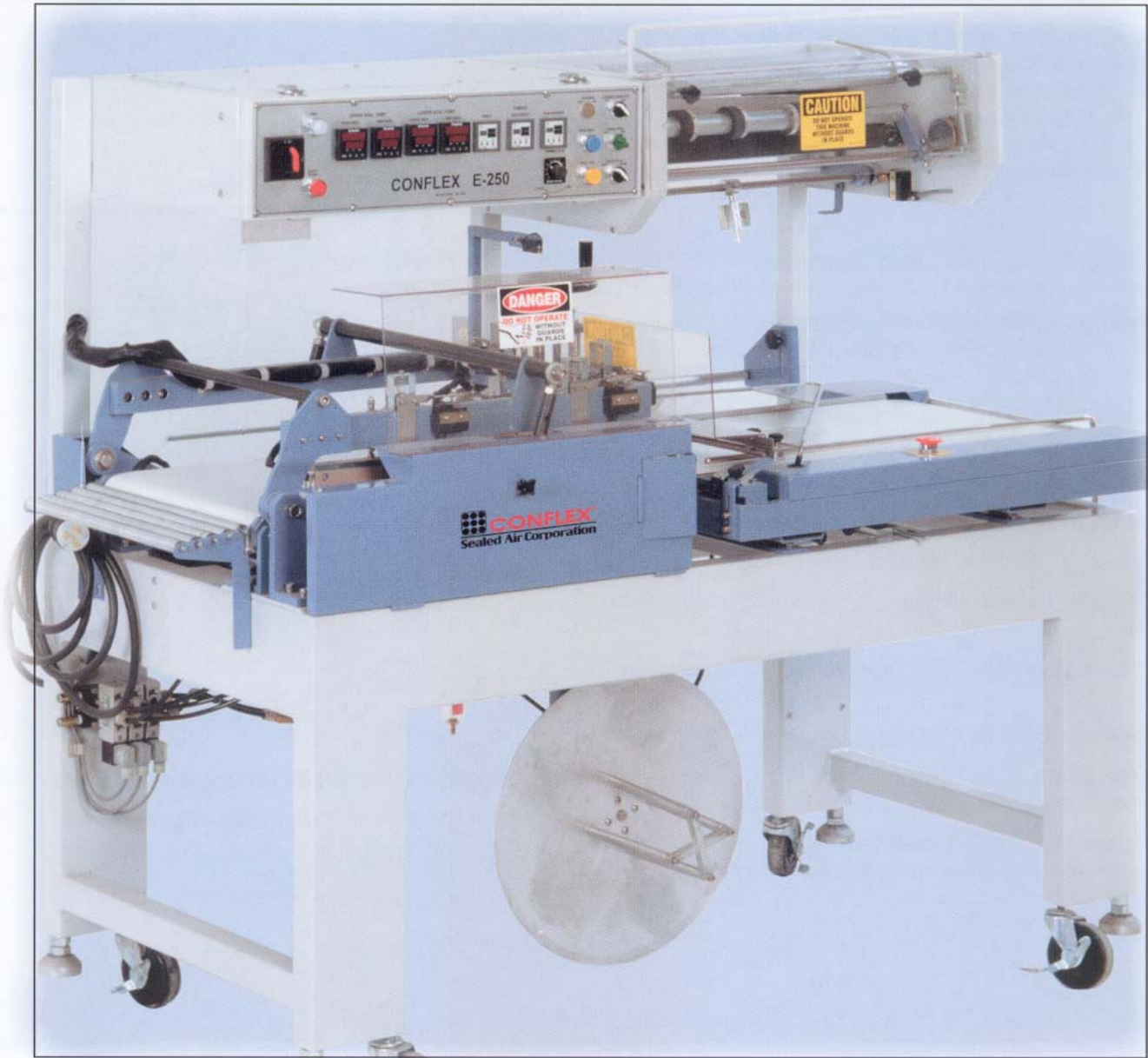

# Sealed Air Corporation

## The Cost-Effective Upgrade You've Been Waiting For!

Fully automatic and engineered for smart performance, the Conflex E-250 L-Bar Sealer is the perfect solution for operations that require a higher level of performance than that of a manual system, but at an economical price. During the sealing cycle, the E-250 "senses" product in its conveyor and temporarily deactivates the belt advance to prevent the next package from entering, facilitating hands-free operation and speeds of up to 30 packages per minute. The E-250...the most efficiency and precision for the price!

## Conflex E-250 Features and Benefits

- **Fully automatic package length adjustments**—Via horizontal or vertical electric eyes; eliminates the need to stop production for adjustments
- **Hot tooled steel knife sealing system**—Eliminates need for wire replacement
- **Lower heated seal pads**—For fast, reliable seals
- **Top mounted control panel**—Provides easy operator access
- **Seals most films**—Polyolefin, PVC and polyethylene
- **Smooth product transfer**—Allows easy wrapping of non-rigid products
- **Film miser/film support bar**—For optimum use and handling of film
- **Small footprint**—A compact 5.5' x 3' size
- **Adjusts to your application**—Features adjustable height legs and casters; hand wheel for product height adjustment
- **Multiple options**—Include wide band seal system, conveyor soft start, film centerfolder, high-speed gearing and more; factory-installed options include closing conveyor, custom infeeds, and more

## Conflex E-250 Specifications

Seal Dimensions	17"W x 22" L
Machine Dimension	65"L x 33"W x 60"H
Net Weight	640 lbs.
Max. Pkg. Ht.	5"
Max. Film Width	20"
Electrical	220V, 16A, 1 ph
Caster Ht.	33-5/8"
Air Requirements (min.)	1 CFM @ 80 psi

## Conflex E-250 Plan View

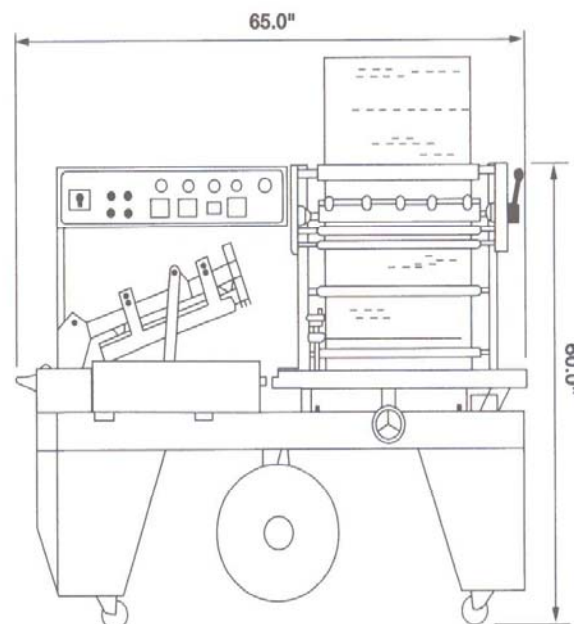

The engineering department is available to customize options for various product applications



**Sealed Air**  
Shrink Packaging Division

Conflex Incorporated  
Manufacturing Facility:

Distributed by: