

EcoWRAP

**Semi-Automatic Rotating Arm
Stretch Wrapping Machine**



ROBOPAC 

overview

The new Robopac Ecowrap semi-automatic rotating arm stretch wrapping machine is designed to handle unstable loads or extremely heavy loads that cannot be wrapped on a traditional turntable machine.

This entry level wrapping unit is ideal for operations currently using hand stretch film and wrapping less than 30 loads an hour.

The Ecowrap features a simple, easy to load, easy to operate roll carriage. The Ecowrap friction roll drive carriage features a simple, mechanical

device mounted on the roll carriage to allow the operator to properly adjust wrapping force for each load.

The Ecowrap is CE Compliant (strictest safety and electrical standards) featuring multiple safety features not found on comparable wrapping machines. The Ecowrap is also equipped with vertical and horizontal bumpers and an electro-mechanical break to immediately stop arm rotation. This innovative safety feature protects your employees and your product from harm.

control panel



The Ecowrap control panel is both intuitive and flexible. Our intuitive design gives your operator access to:

Functions including:

- Up and down carriage speed
- Top wraps (0-10)
- Bottom wraps (0-10)
- Manual film carriage and reinforcing wraps
- Adjustable photocell delay

Wrapping cycles and custom programs:

- Up and down wrapping cycle
- Up only wrapping cycle
- Only top and/or bottom cycle
- Manual cycle

film carriage

Friction Roll Drive

The Ecowrap roll carriage is designed to run lightweight, prestretched, ultra-thin films.

The Ecowrap can also utilize standard film rolls that weigh less than 13 lbs.

The new lightweight films reduce your film costs and make it easier for operators to load film.

The Ecowrap friction roll drive allows your operator to quickly and



easily adjust the wrapping force to ensure the proper wrapping of your loads.

pallet guide



Side load pallet guide allows easy and precise positioning of your load.

The guide allows you to easily and precisely drop your load from either side or from the front.

Side guide

specifications

Technical Features	
EcoWrap	
Performance	
Production Speed	Up to 30 LPH
Arm Rotation Speed	7-11 RPM
Up/Down Carriage Speed	8.5-19.5 ft/min
Load Handling	
Maximum Load Size	40" x 48"
Maximum Load Height	78.75 inches
Maximum Load Weight	Infinite
Film Delivery System	
Film Delivery System	Friction Roller Drive
Standard Pre-Stretch	100%
Wrapping Force	Variable Mechanical
Load Height Detection	Electric Photo Eye
Maximum Roll Weight	13 pounds
Maximum Roll Diameter	9.75 inches
Maximum Roll Height	19.75 inches
Maximum Film Gauge	130 gauge
Safety Features	
Safety Bumper with dual circuits	Standard
CE Compliant	Yes
Self-braking Motor	Standard
Emergency Stop Button	Standard
Vertical and Horizontal Safety Bumpers	Standard
Service Requirements	
Electric	110V 1 phase
NEMA 12 Enclosure	Standard
Warranty	3 Years

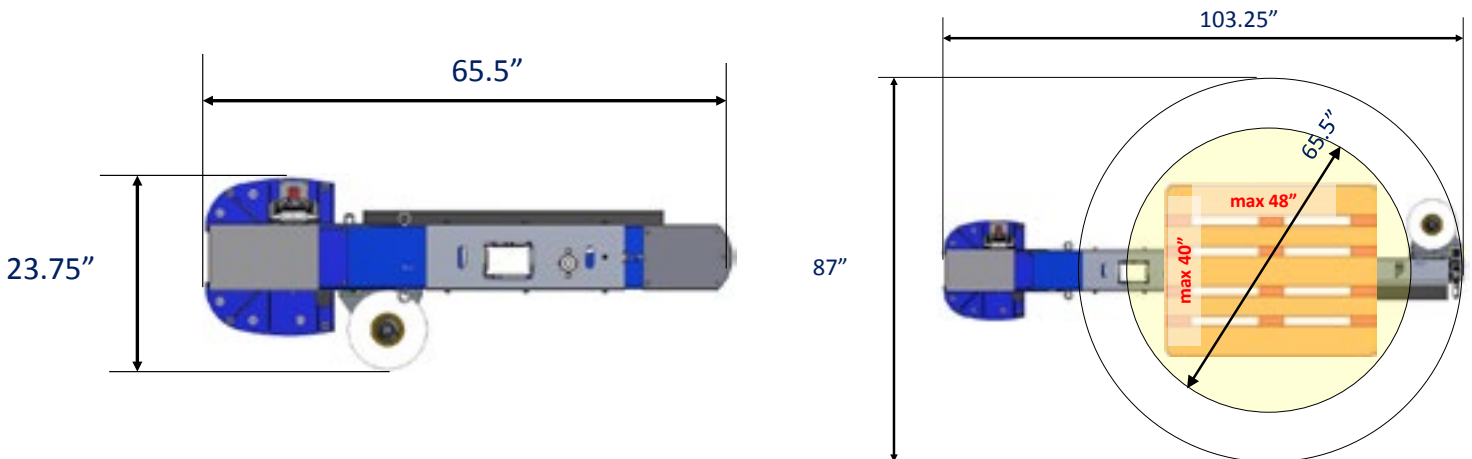

ROBOPAC

Robopac is the global leader in the stretch wrapping industry. Our line of semi-automatic and automatic stretch wrapping equipment combines technology, innovation and experience into products that deliver results you can depend on.

Robopac is ISO 9001:2008 certified and all our equipment meets the strictest global safety standards, including CE.

In 2008, Robopac hired Porsche Lean Consulting to help us implement their lean manufacturing process in our factory. This process allows us to build our equipment faster, better, for less.



Aetna Group holds over 100 patents and our commitment to innovation is the heart of our organization. With over 80 employees dedicated to Research & Development and a \$7.6-million investment in R&D in 2011, we are committed to maintaining our position as the global leader in secondary packaging.

Aetna Group has more than 120,000 machines installed around the world and currently produces 6,700 machines annually, more than twice that of our nearest competitor.

Our four product lines: Robopac, Robopac Sistemi, Dimac and Prasmatic offer complete lines of innovative stretch wrapping systems, bundlers, shrink wrappers, cartoning systems and tape machines through a global network of over 400 agents and distributors. We also employ over 80 technical service engineers ready to provide prompt and courteous support, whenever and wherever you need it.

AETNA GROUP U.S.A. Inc.

2475B Satellite Blvd. - Duluth - GA 30096-5805 - USA
tel: (+1) 678 473 7896 - toll free (866) 713 7286
fax: (+1) 678 473 1025
e-mail: aetnagroup@aetnagroupusa.com

ROBOPAC S.P.A.

Via Fabrizio da Montebello, 81
47892 Acquaviva Gualdicciolo - Repubblica di San Marino
tel: + 378 0549. 910. 511
fax: + 378 0549. 908. 549 / 905. 946
e-mail: robopac@aetnagroup.com

AETNA GROUP S.P.A. - ROBOPAC SISTEMI

S.P. Marecchia, 59 - 47826 Villa Verucchio - Rimini
tel: (+39) 0541 673411
fax: (+39) 0541 679576
e-mail: robopacsistemi@aetnagroup.com

AETNA GROUP S.P.A. - DIMAC

Via Rinascita, 25 - 40064 Ozzano Emilia - Bologna
tel: (+39) 051 791611
fax: (+39) 051 6511013
e-mail: dimac@aetnagroup.com

PRASMATIC S.R.L.

Via J. Barozzi, 8 - Z.I. Corallo - 40050 Monteveglio - Bologna
tel: (+39) 051 960302
fax: (+39) 051 960579
e-mail: info@prasmatic.com

AETNA GROUP UK LTD

Packaging Heights
Highfield Parc- Oakley- Bedford MK43 7TA - England
tel: (+44) 0 1234 825050
fax: (+44) 0 1234 827070
e-mail: sales@aetna.co.uk

AETNA GROUP FRANCE S.a.r.l.

4, Avenue de l'Europe - 69150 Décines - France
tel: (+33) 04 72 14 54 01
fax: (+33) 04 72 14 54 19
e-mail: commercial@aetnafr.aetnagroup.com

AETNA GROUP DEUTSCHLAND GmbH.

Liebigstr. 6 - 71229 Leonberg - Höfingen - Germany
tel: (+49) 0 7152 33 111 30
fax: (+49) 0 7152 33 111 40
e-mail: info@aetna-deutschland.de

AETNA GROUP VOSTOK OOO

129329 Moscow - Otradnaya str. 2B - building 6 office 224
tel: (+7) 495 6443355
fax: (+7) 495 6443356
e-mail: info@aetnagroupvostok.ru

AETNA GROUP SHANGHAI

Shanghai Jin Shan Industrial Park
Jin Liu Road No 877 - 201506
tel: +86 (0) 21 67290111
fax: +86 (0) 21 67290333
e-mail: infochina@aetnagroup.com

www.aetnagroupusa.com

